

ECHOPHONE RADIO MFG. CO.

MODEL EC-1

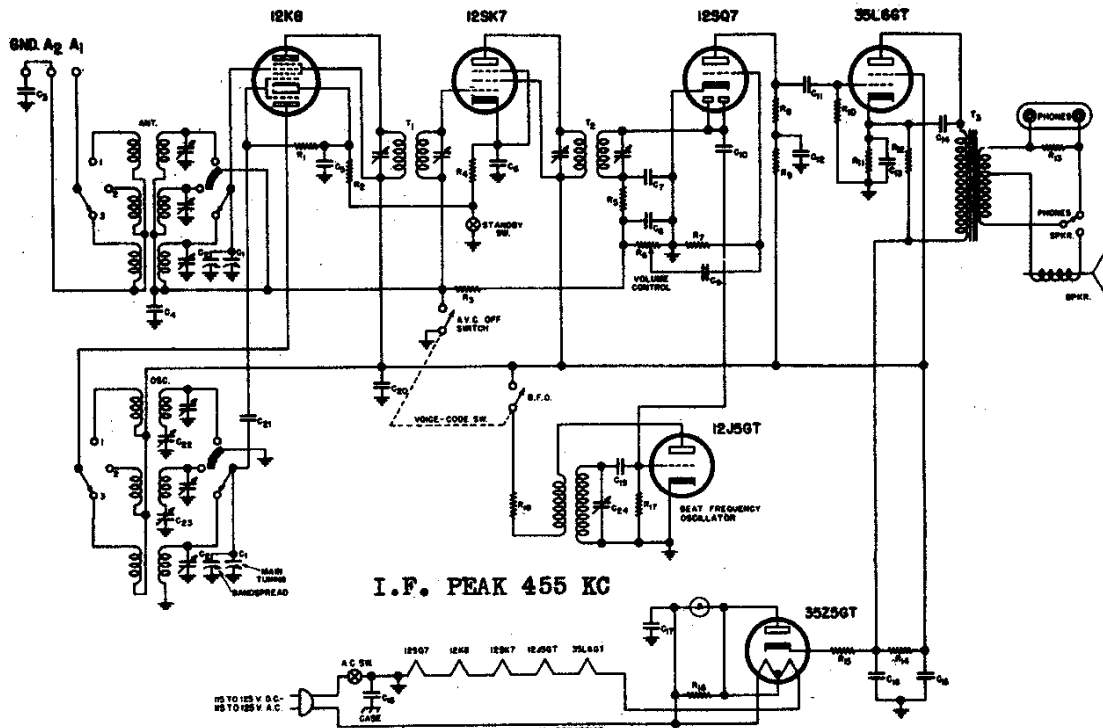

I.F. PEAK 455 KC

C1	530 mmf	Main tuning	16	40.	mfd	150	4	400
2		Band Spread	17	.02	mfd	400	5	50,000
4	.01 mfd	400	18	.25	mfd	200	6	500,000
5	.05 mfd	200	19	150	mmf	Section of C24	7	10,000,000
6	.02 mfd	400	20	.05	mfd	200	8	250,000
7	.05 mfd	200	21	50	mmf		9	100,000
8	100 mmf		22	600	mmf	Pad	10	500,000
9	.005 mfd	200	23	1,900	mmf	Pad	11	150
10	10 mmf		24	450	mmf	BFO Trimer	12	7,500
11	.01 mfd	400					13	15
12	.05 mfd	200					14	750
13	20. mfd	25	R1			50,000	15	25
14	.01 mfd	400	2			300	16	300
15	30. mfd	150	3			2,000,000	17	50,000
							18	500



TRIMMER LOCATION

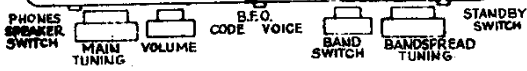
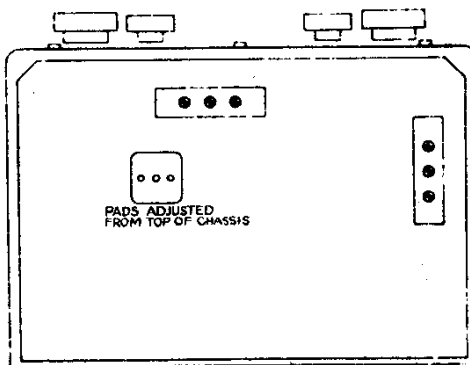
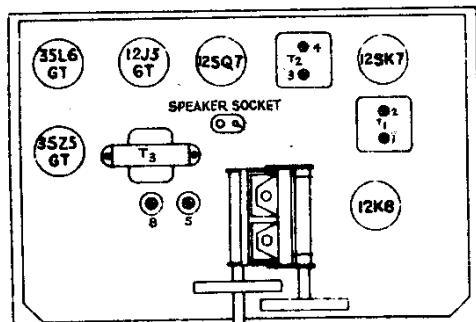

MODEL EC-1

ECHOPHONE RADIO MFG. CO.

Alignment Procedure

EQUIPMENT NEEDED FOR ALIGNING:

- * An all wave signal generator which will provide an accurately calibrated signal at test frequencies listed.
- * Output indicating meter.
- * Non-metallic screw driver.
- * Dummy antennas 400 ohm, 200 mmfd and .1 mfd.
- * Volume control - Maximum all adjustments.
- * Connect B - of radio chassis to ground post of signal generator through .1 mfd. condenser.
- * Connect Dummy antenna value in series with generator output lead.
- * Connect output meter across primary of output transformer.
- * Allow chassis and signal generator to "heat up" for several minutes.

<u>BAND</u>	<u>Signal Generator</u> Frequency Setting	<u>Dummy</u> <u>Antenna</u>	<u>Pad</u>	<u>Trimmers</u>	<u>Adjustment</u>
I.F.	455 kc	.1 mfd.	none	# 1-2-3-4 on top of IF can	Adjust to maximum output
1	600 kc 1800 kc	200 mmf 200 mmf	#5 none	none #6-7	maximum output maximum output
2	2.5 mc 7.0 mc	400 ohm 400 ohm	#8 none	none #9-10	maximum output
3	no padding condenser on this band 28 mc	400 ohm		#11-12	maximum output

Specifications

Power Consumption	35 watt
Power Output	600 milliwatts undistorted
Sensitivity (for .05 watts output)	20 microvolts average
Selectivity	54 kc at 1000 times down at 1000 kc
Frequency Range	545 kc to 30.5 mc
Intermediate Frequency	455 kc
Speaker	5 inch FM dynamic

NOTES ON OPERATION

ANTENNA: This receiver will require a piece of wire connected to A-1 terminal of the antenna terminal strip appearing on the rear apron of the receiver's chassis. Very satisfactory operation of the receiver throughout its 3 band tuning range will be secured by using an outside antenna approximately 50 to 75 feet long including lead-in. This antenna should be erected as high as possible and removed from surrounding objects. Be sure the antenna is insulated from the ground at all points. For minimum interference it should be at right angles to street car lines, power lines and other electrical apparatus in the vicinity. When using this type of antenna the jumper between A2 and G terminals should remain connected. A doublet antenna can be used and should be connected to terminals A1 - A2. The jumper can remain connected between A2 and G or removed depending upon its favorable effect on reception. A ground can be connected to the G terminal and should be used only when it materially improves the operation of the receiver.

BANDSPREAD: This control will be of most help on the higher frequencies covered by bands 2 and 3. The bandspread control varies in much smaller quantities the capacity of the main tuning condenser. For fine adjustment the bandspread control will prove to be of great help. When this control is adjusted a pointer moves horizontally in front of a numbered scale which is at the bottom of the main dial. This scale can be used for reference points and should be used in conjunction with the logging scale appearing on the outer edge of the main dial. **NOTE:** The bandspread pointer should be left at 0 if the main dial calibration is to be accurate. When the bandspread control is used the main tuning dial pointer should be left at a frequency slightly higher than the desired signal - operating the bandspread control will then enable you to easily and accurately tune in the signal.

BFO - ON-OFF: CODE-VOICE switch in the ON position disconnects the automatic volume control or AVC circuit and also supplies a beat note for the copying of code or CW stations. This feature will be of help in locating weak broadcasting or phone signals. After they are located the switch should be thrown to the VOICE position which will remove the BFO whistle.

NOTE: The EC-1 Receiver can be used as a test code oscillator by connecting a Mackey in series with the phones. The BFO switch should be placed in the CODE position and a broadcast station carrier tuned in. Operation of the key will then provide a signal which will sound like CW code transmission.

STANDBY: This switch is used should the receiver be operated in conjunction with a transmitter and makes the receiver inoperative during transmission periods by removing the plate voltage from the tubes.